

PACKAGING TIPS:

PALLETS

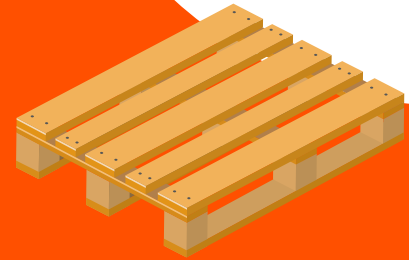

Individual items weighing 70kg or above must be palletised for safety purposes and to make sure your goods are protected during transit. Shipments are likely to be handled multiple times via forklifts before they reach their final destination, so the correct packaging of this freight is essential.

- The recommended pallets for TNT are either:
 - UK standard pallets which are 120 cm in length x 100 cm in width x 15 cm in height. The maximum weight that can be safely carried on these types of pallets is 1,000 kg and the maximum height should not exceed 180 cm
 - The European (Euro-size) standard pallets which are 120 cm in length x 80 cm in width x 15 cm in height. The maximum weight that can be safely carried on a Euro-sized pallet is again 1,000kg with the maximum height not exceeding 180cm
- The pallet must elevate the load at least 15cm from the ground so that it will allow handling by either a forklift or pallet truck.
- A pallet can be made from various materials such as wood, plastic, metal, fibreboard or corrugated pallets. TNT prefers the standard wood constructed pallets with four way entry capabilities. Please avoid using pallets which are made from chipboard or polystyrene.

CONSTRUCTING A PALLET

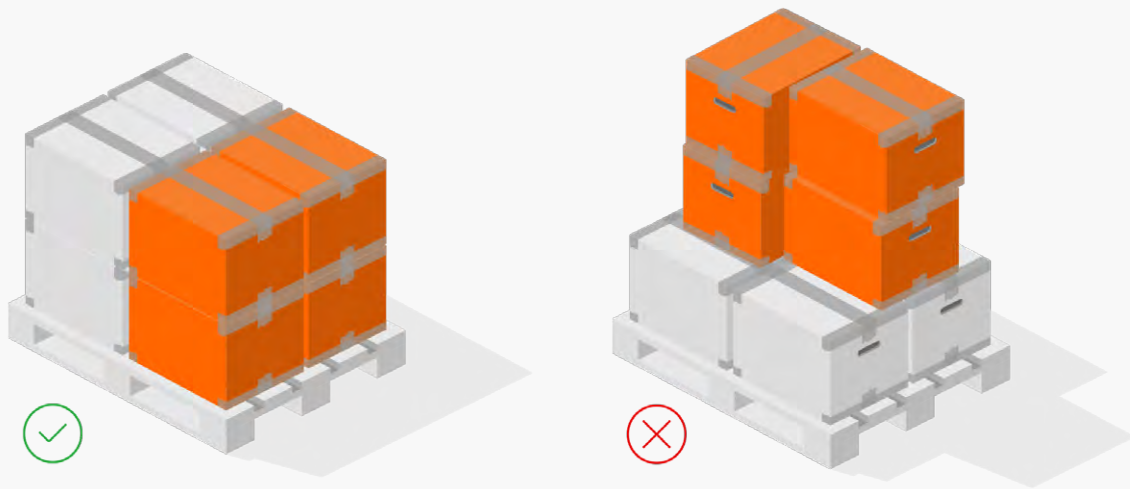

- Check all pallets before use for any signs of wear and tear.
-

The proper construction of a pallet is crucial as this will have a significant impact on the integrity of the shipment:

- The correct method to ensure stability and strength is to stack boxes in columns. This involves placing boxes directly on top of each other to form a 'cube' shape, making sure the load has a flat surface at the top. Please check that the boxes fit correctly on the pallet and do not overhang the edge of the pallet.
 - Boxes should only be stacked overlapping each other, known as the 'bricklayer' method if the individual cartons and their contents form a rigid unit.
 - Please note when palletising boxes, if a box is only partially filled it can easily become crushed under the weight of other parcels on the pallet. Therefore, any empty space in a box should be filled with suitable cushioning materials i.e. foam, corrugated cardboard etc.
 - Avoid building 'pyramid' shape pallets as the lack of a level surface weakens the overall packaging and may expose the contents to damage from other shipments.
-

BANDING

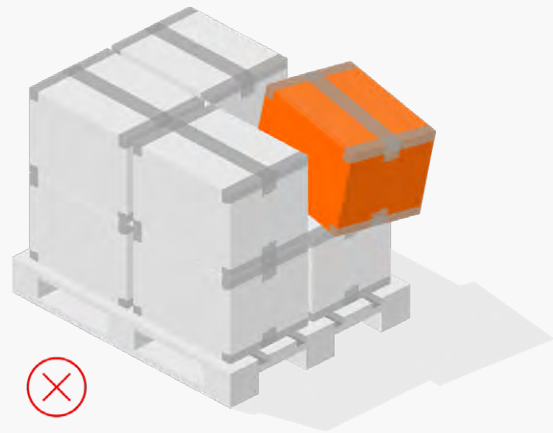
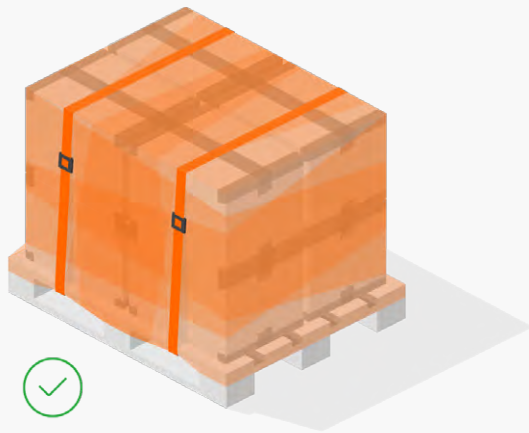

Usually any damage caused to palletised boxes during transit is due to the shipment not being correctly stacked, bundled or secured.

TNT recommends the following guidelines for protecting, shrink wrapping and banding:

- Top and bottom load protector pads help to reduce damage to the top and bottom of the shipment. Corner or edge boards which should run the full length of the pallet help to stabilise the load and protect the box edges at each corner of the pallet.
- Banding is generally used to secure the bundled load to the pallet. Strapping can be applied around several decking rows for additional stability. There are various forms of banding including steel, polypropylene, nylon or polyester. Heavy duty strapping such as steel is preferred for heavy loads as it does not stretch.

SHRINK-WRAPPING

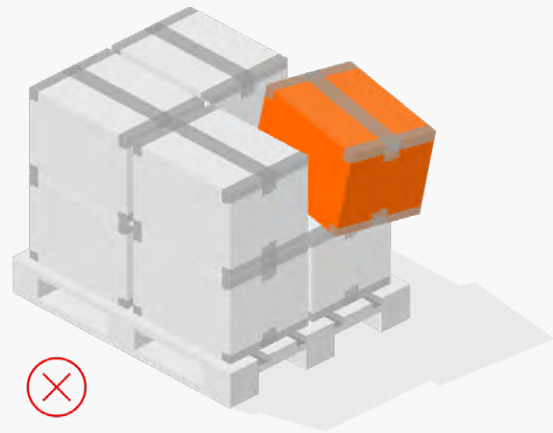
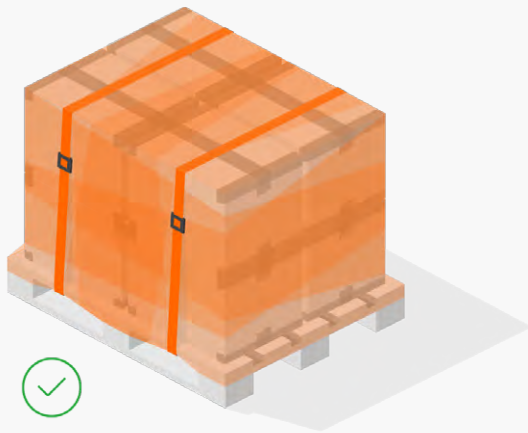

- Shrink-wrapping is critical for bundling the load and securing the items to the pallet. It is a packaging technique which involves wrapping thin, stretchable plastic film, tightly around the load.

The shrink-wrap should be tucked between the pallet and the bottom row of boxes or tied to the bottom of the pallet. The wrap should be spiralled around the boxes in an upward direction making sure the film overlaps. At the top of the load, stretch the film diagonally over the corners and then spiral back down to the bottom leaving a slight overlap at the pallet base. As a minimum, there should be 3 layers of shrink wrap.

- An alternative to shrink-wrapping is to use secondary outer packaging as this will provide added protection. The outer packaging will need to be fastened by either gluing or stapling the base of the package to the pallet to make it secure. The boxes should then be evenly distributed inside the outer packaging making sure the contents are tightly packed to avoid movement. The top of the packaging should be levelled and then the lid secured.

LABELLING OF FREIGHT



- Make sure the routing labels are placed on the side of the pallet load and clearly visible to enable the barcode to be scanned
- Use orientation labels to help us with the identification of the type of freight and required handling practices such as 'This Way Up'; 'Fragile; Handle with Care'.

CRATES

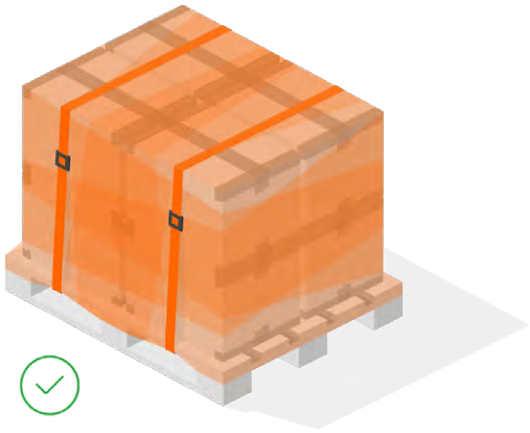

- The use of crates is an ideal approach to protect your shipment from damage. The design and materials used in constructing a crate must take into account the weight of the items to be carried in the container.
- Transit crates should be shrink wrapped and banded to a pallet.

DRUMS

SINGLE

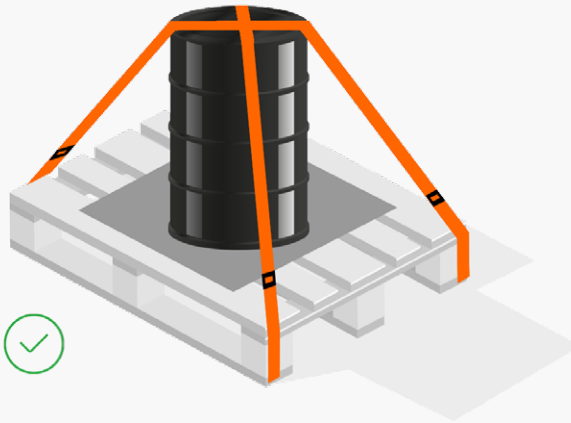

GROUP



- All drums must be secured to a pallet. The drum should be placed as close as possible to the centre of the pallet ensuring there is no overhang. Liquid filled drums can be very heavy and care must be taken not to exceed the pallet weight capacity.
- A corrugated sheet should be placed between the drum and pallet in order to reduce wear and prevent punctures caused by the decking fasteners. The sheet should not be any smaller than the base of the drum.
- Multiple drums must be bundled tightly together to create one unit, which is easier to secure. Use an interface material between the strapping and drum to distribute the load and prevent slipping. Keep strapping as close to the drum sides as possible to limit shifting of the load and to protect from damage.

PIPES

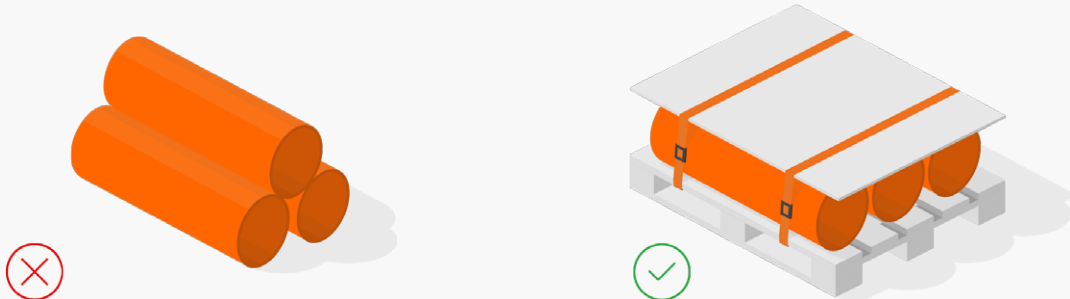

- **These types of shipments require special packaging to prevent the product from damaging other shipments during transportation.**
- Pipes should be secured to a wooden pallet
- Two or more items should be bundled together as this will increase the integrity of the load and can reduce damage
- Blocking materials should be used to brace the items against the pallet so they remain fixed during transit
- Use strapping materials to secure the bundled items to the pallet.

SPOOLS & REELS

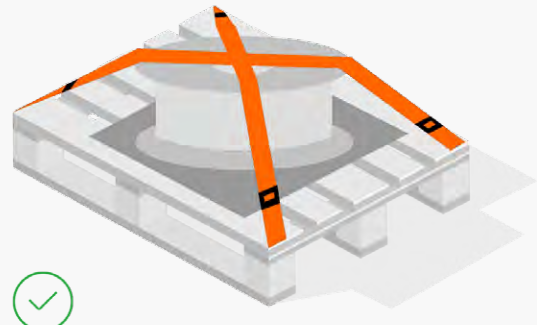
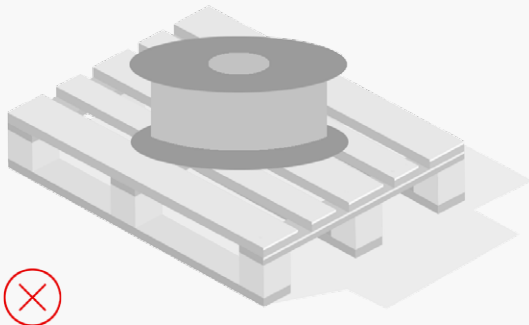

- Due to their shape, spools and reels can move during transit and given the weight they are difficult to lift without mechanical assistance. These items must therefore travel either on their side or facing forward secured to a pallet.
- Blocking should be placed tightly against the object being secured, to prevent any movement.
- Fasteners should be used to secure the blocking and item to the pallet.
- The goods should be strapped into place preferably with steel strapping.